

Southco® Push to Close Latches

Dual-side Latching

- Lift paddle to open
- Left- or right-hand latching in one assembly available
- Durable, corrosion-resistant materials
- Keylockable with locked/unlocked indicators
- Paddle serves as the door handle

Push to Close Latches
Visible

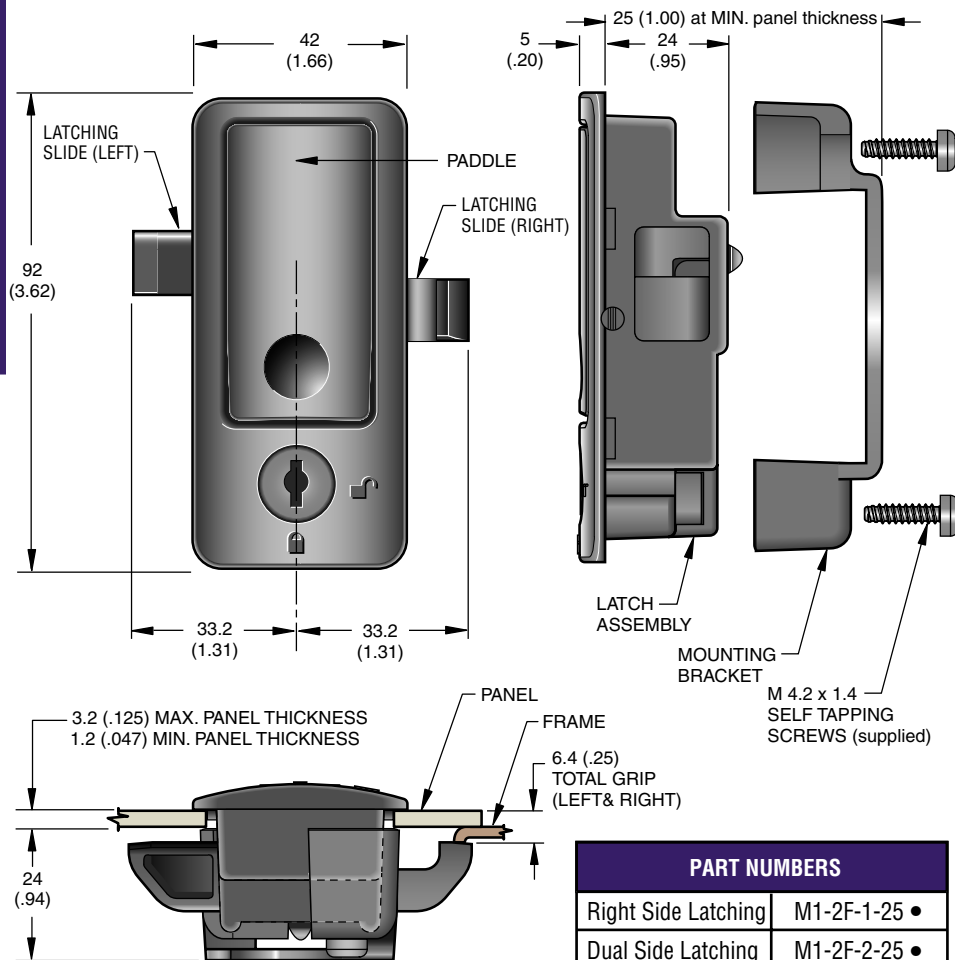

PART NUMBERS	
Right Side Latching	M1-2F-1-25 •
Dual Side Latching	M1-2F-2-25 •
Left Side Latching	M1-2F-3-25 •

Complete latch assemblies are individually packaged. For bulk packaging (20 per box) add -3 to part number. Custom color matching available, contact Southco for details.

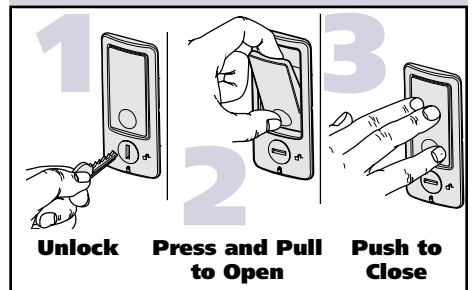

Material and Finish

HOUSING and PADDLE: Polycarbonate/ABS resin, black.
 LATCHING SLIDES, LOCKING ARM and MOUNTING BRACKET: Glass reinforced nylon, black.
 LOCK PLUG: Glass reinforced acetal, black, with brass wafers.
 KEYS: Brass, nickel plated.
 SCREWS: 410 Stainless steel, passivated.

Product Strength Guidelines

(To assist in your product selection; samples are available for your evaluation.)

Maximum static load: 500 N (112 lbs.)
 Average ultimate load: 875 N (195 lbs.)
 Maximum Tightening Torque for Mounting Screws: 1.8 N·m. (16 in.-lbs.)

Flammability Rating: UL 94 - HB

millimeter (inch)
 millimeter (inch)

Dimensions without tolerances are for reference only.

Installation

1. Prepare opening in panel as shown*. Note the location of frame or latching surface with respect to left- or right-side latching.
2. Place assembly into panel opening by squeezing latching slides together. Apply mounting bracket and secure entire assembly with screws provided, (Self tapping combination Torx® T15 Recess with slot).

* Fits the same mounting hole/panel preparation as E1-10-101-50 and E1-10-102-50.

Torx® is a registered trademark of the Camcar Division of Textron Inc.

